



Tailor made for retail and public environments

With the MultiQ 212, MultiQ have taken custom made monitor solutions for retail and public environments one step further. The product offers a solid, stable and very flexible display screen combined in a compact and elegant design. Metal housing and protective glass gives MultiQ 212 a unique durability even in the most demanding environments.

MultiQ have combined many years of experience of retail, public environments and demands from our customers. The result is a monitor that answers very well to the challenges of public environments. MultiQ 212 is designed for 24/7 operation (24 hours a day, 7 days a week) and is suitable for retail environment with its metal housing. The monitor is prepared for Kensington

lock and can be mounted onto the surface when using stand. With MultiQ 212 you can easily hide the cables through the stand and, for example, down under the table.

MultiQ 212 offers several features to improve the ergonomics. Great tilting angle improves the ergonomics which makes it possible to work standing up.

This MultiQ 212 B-9 has a black casing and is equipped with capacitive touch glass (USB), black card reader (MSR USB Hid), power USB-hub and switches on the back.

Capacitive touch screens outer conductive layer is quite insensitive and don't easily get scratched or wear out. This means they can be used in unsupervised areas. The touch can be initiated by a finger touch.

MultiQ 212 B-9

Technical specifications

Display	
Panel type	12.1" LCD TFT
Active display area	246,0 (H) x 184,1 (V) mm
Resolution	SVGA, 800 x 600 max.
Brightness	400 cd/m ² (Typ.)
Contrast ratio	600:1 (Typ.)
Viewing angle	(CR 10:1) H:-80°~80° (Typ.) (CR 10:1) V:-60°~50° (Typ.)
Number of colours	262.144 colours, 6 bits
Response time	35 ms Tr+Tf (Typ.)
Pixel dimension	0,3075 (H) x 0,3075 (V) mm
OSD Control	Auto Set, Brightness, Contrast, Colour, Position, Image, Miscellaneous.
Hot keys functions	Control key locking, Quick brightness and contrast adjustment, Auto Set.
Lamp life	50.000 h (min)
MTBF	50.000 h

Input Signal	
Video signal	Analog 0,7 V _{p-p} . 75 ohm
Sync. signal	TTL Level, Positive/Negative, Separate sync (VGA)
Connector	VGA (15-pols D-sub) Power USB (9-pols D-sub) USB

Dimension	
With stand	281 (H) x 298 (W) x 129 (D) mm
With VESA	250 (H) x 298 (W) x 48 (D) mm
Tilt with stand	+70°,-0°

Weight (Net)	
With stand	4,3 kg
With VESA	3,3 kg

Environment	
Operating temperature	0 - 40°C
Transport & Storage	Ambient Temp: -10 - +60°C Humidity Range: 10 - 100%

General	
Plug & Play	DDC2B
Included accessories	VGA cable - 1,8 m (black), Power USB cable - 3 m (black).
Regulations	Safety: UL/Tüv-GS, EMI: CE/FCC, ISO 13406-2.
Warranty	3 years SendIT
Security	Table locking (stand), Kensington locking capability.
Touch	Capacitive USB
Mounting	Stand
MSR	MagTek 3 tracks, USB Hid
Power	Power USB-hub
Part no.	FPD102659

Additional accessories

Swivel plate, POS-Pole, VESA, Wall bracket kit

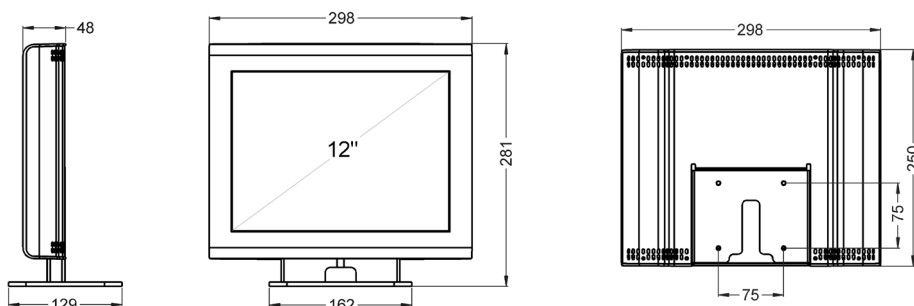

RoHS Compliant 2002/95/EG

©2009 MultiQ are registered trademarks or trademark applications of MultiQ International AB in various jurisdictions. All other company names and products are trademarks or registered trademarks of their respective companies. We reserve the right to change the specifications without prior notice.